

# 13000X778 series

High performance pushbutton switches - threaded bushing Ø 11,9 (15/32)

*Distinctive features*

UG1006-A

## □ Agency approvals



CECC 96401-001

This range of professional switches is suitable for use in military and other high specification environments.



## □ Contacts

Highly reliable contacts suitable for low level applications (10mA 50mV, 10µA 5VDC min.) or power applications (2A 250VAC, 4A 125VAC, 4A 30VDC max.)

## □ Double shell case

For high mechanical strength and high electrical insulation.



## □ Compact size

The small rear end of the switch allows space savings behind the panel.

## □ Finish

Matt black finish on body, bushing, plunger and hardware.

## □ Full sealing

Panel sealed to IP 67, these switches are frontal sealed by three O-rings and have full rear end sealing.

# 13000X778 series

High performance pushbutton switches - threaded bushing  $\varnothing$  11,9 (15/32)

Specifications

## ELECTRICAL SPECIFICATIONS

- Max. current/voltage rating with resistive load : 2A 250VAC - 4A 125VAC - 4A 28VDC
- Minimum load : 10mA 50mV, 10 $\mu$ A 5VDC  
When used above 300mA 28VDC, the gold plating is removed on contact areas and is considered only as a protection against oxidation during storage.
- Initial contact resistance : 10 m $\Omega$  max.
- Insulation resistance : 1.000 M $\Omega$  min. at 500VDC
- Dielectric strength :  
1.000 Vrms 50 Hz min. between terminals  
2.000 Vrms 50 Hz min. between poles  
2.000 Vrms 50 Hz min. between terminals and frame
- Contact bounce : 2 ms max.
- Electrical life :
  - At 2A 250VAC - 4A 28VDC : 10.000 cycles
  - At low level (50mV 10mA) : 150.000 cycles

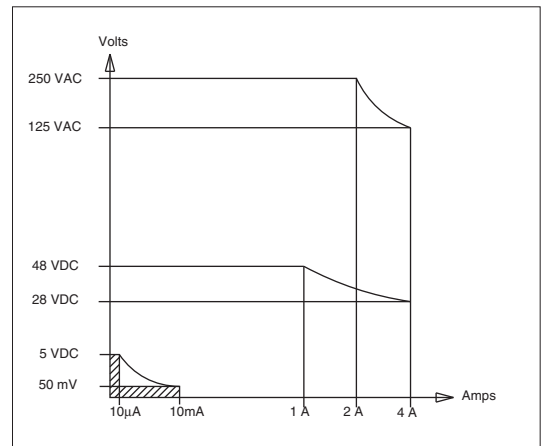

## MATERIALS

- Case : diallylphthalate (DAP) with PBT external shell (epoxy sealed)
- Actuator : brass, black chrome plated
- Bushing : brass, black chrome plated
- Contacts : silver inlay - gold plated over nickel barrier

## SEALING

- Front panel sealing by three O-rings
- Panel seal withstands 1 bar pressure and remains sealed even when the switch is operated.
- Epoxy sealed terminals
- Splash-proof case

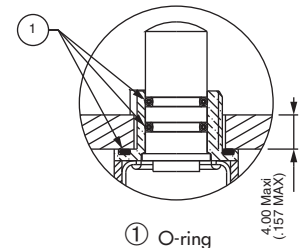

## GENERAL SPECIFICATIONS

- Total travel : 2 mm (.078)
- Torque : 1,50 Nm (1.10 Ft.lb) max. applied to nut
- Panel thickness : 5 mm (.196) max.
- Shock test : 50g - 11 ms (IEC 68-2-27)
- Vibrations : 10-500 Hz - 10g (IEC68-2-6)
- Operating temperature : -40 $^{\circ}$ C to +85 $^{\circ}$ C
- Humidity test : 56 days, 93 % R.H., 40 $^{\circ}$ C (IEC 68-2-3)
- Salt spray test : 96 hours (IEC 68-2-11)

## APPROVALS

Many models within this range have full CECC approval. To order switches marked CECC, complete appropriate box of ordering format.

# 13000X778 series

High performance pushbutton switches - threaded bushing Ø 11,9 (15/32)

Overview

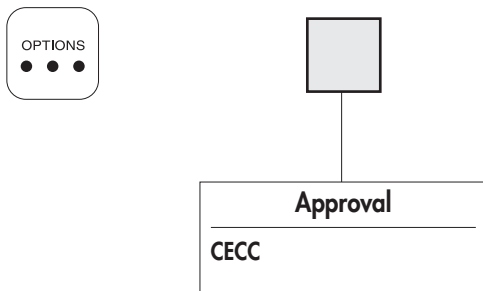
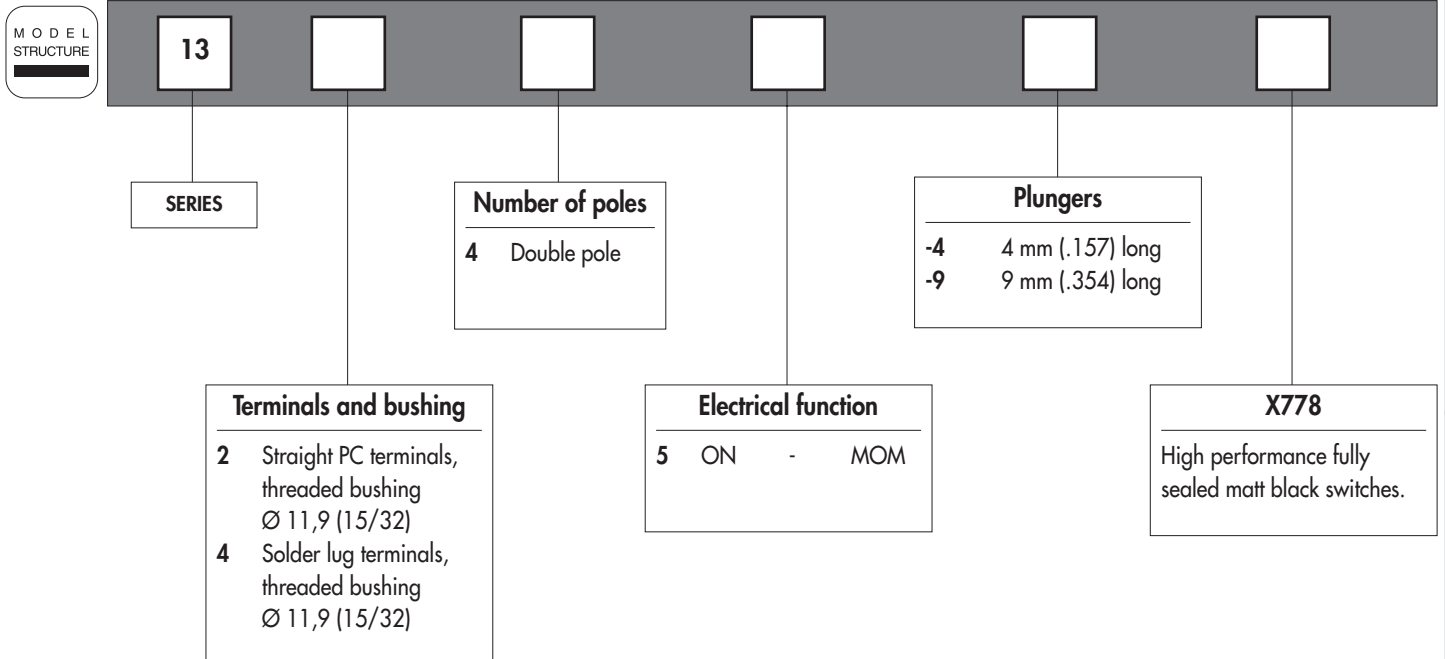

## ABOUT THIS SERIES

On the following pages, you will find successively :

- model structure of switches
- options in the same order as in above chart

**Dimensions** : first dimensions are in mm while inches are shown as bracketted numbers.



**Sealing boots** can be used to further protect the switches against dust and water. They are presented in section H.



**Mounting accessories** : standard hardware supplied with all models : 1 hex nut 14 (.551) across flats, part number U41. This nut is presented after model structure of switches.



**Security cap** available to prevent inadvertent plunger operation. See section I.

**Packaging unit** : 25 pieces

# 13000X778 series

High performance pushbutton switches - threaded bushing  $\varnothing 11,9$  (15/32)

Fully sealed - matt black

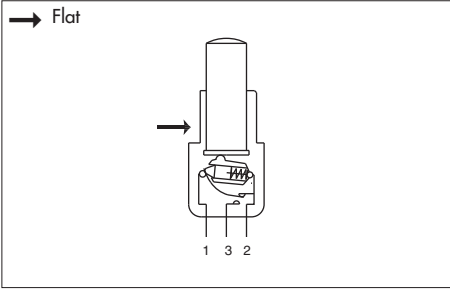

• Quick-break momentary pushbutton switches

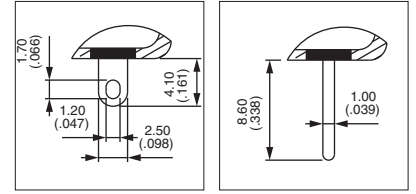

MODEL STRUCTURE



B

Solder lug terminals - double pole - 4 mm (.157) plunger → Flat



13445-4X778

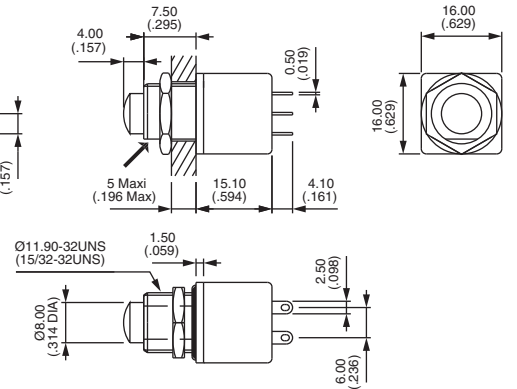
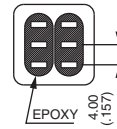
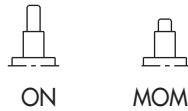

Solder lug terminals - double pole - 9 mm (.354) plunger → Flat



13445-9X778

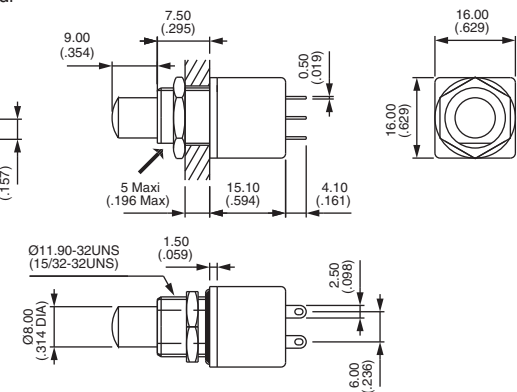
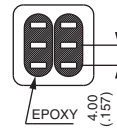
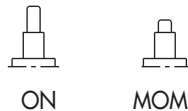

Straight PC terminals - double pole - 4 mm (.157) plunger → Flat



13245-4X778

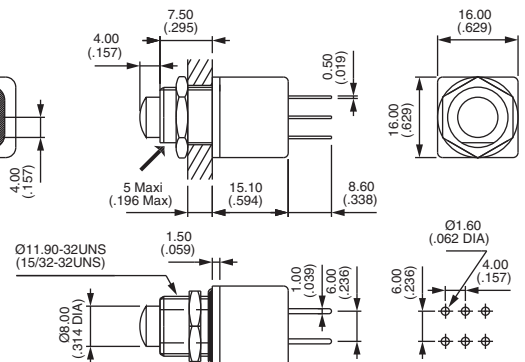
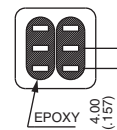
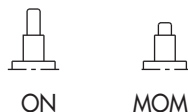

# 13000X778 series

High performance pushbutton switches - threaded bushing  $\varnothing$  11,9 (15/32)

Fully sealed - matt black

Straight PC terminals - double pole - 9 mm (.354) plunger → Flat



13245-9X778

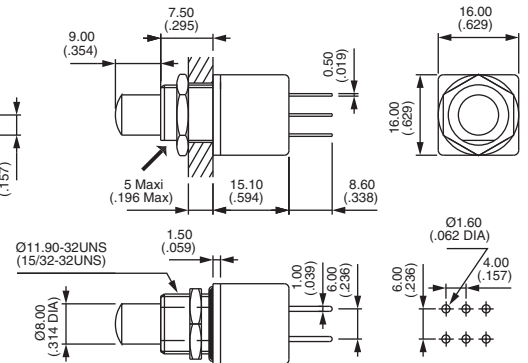
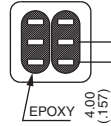

## PANEL CUT-OUT

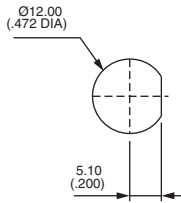

## STANDARD HARDWARE

Hex nut

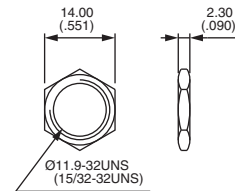

U41 (matt black)

## POSITIONS AND CONNECTIONS

FUNCTION	BUTTON POSITION AND CONNECTIONS		TERMINAL IDENTIFICATION
	I	II	
13245 13445	ON A 1-2 B 1-2	MOM A 1-3 B 1-3	→ Flat 

## AGENCY APPROVAL

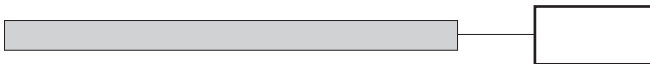

CECC CECC 96401-001

**Marking** : to order switches marked CECC, please complete above box with "CECC".  
Blank : no agency approval required.